

Beam Couplings

Single Beam Couplings • Double Beam Couplings • Cross-Slotted Couplings



Edition 2024/2025

Table of Contents

Introduction									Page
Introduction									3
Single Beam Couplings	Material		Torques Nm	Max. speed min ⁻¹	Permissible shaft misalignment			Temperature range °C	Page
	Aluminium	Steel, stainless			Axial mm	Radial mm	Angular °		
with set screw									
RBC ... EWS-ALU	●		4,6	10000	± 0,25	± 0,25	5	-40 - 100	4
RBC ... EWS-STE		●	8,9	10000	± 0,25	± 0,25	5	-40 - 300	6
with clamp									
RBC ... EWC-ALU	●		4,9	10000	± 0,25	± 0,25	5	-40 - 100	8
RBC ... EWC-STE		●	8,9	10000	± 0,25	± 0,25	5	-40 - 300	10
Double Beam Couplings	Material		Torques Nm	Max. speed min ⁻¹	Permissible shaft misalignment			Temperature range °C	Page
	Aluminium	Steel, stainless			Axial mm	Radial mm	Angular °		
with clamp									
RBC ... DWC-ALU	●		12,0	3 600	± 0,25	± 0,75	5	-40 - 100	12
RBC ... DWC-STE		●	23,5	3 600	± 0,25	± 0,75	5	-40 - 300	14
Cross-Slotted Couplings	Material		Torques Nm	Max. speed min ⁻¹	Permissible shaft misalignment			Temperature range °C	Page
	Aluminium	Steel, stainless			Axial mm	Radial mm	Angular °		
with clamp									
RBC ... FKC-ALU	●		2,0	10000	± 0,25	± 0,15	3	-40 - 100	16
Beam Coupling Technology Details									Page
Technical points									18
Customized Beam Couplings and Precision Springs									Page
Customized Beam Couplings									21
Questionnaires for customized Beam Couplings									23
Examples of various customized Beam Couplings									24
Use of beam technology for customized Precision Springs									25

Issue 06/2024 – Technical details subject to change without notice

RINGSPANN Beam Couplings are machined from a single piece and made from homogeneous materials. Their basic form consists of a cylindrical body, into which a helix slot (beam) is cut. This beam shape gives rise to a precise flex zone, resulting in an elasticity that can be precisely calculated.

The «advantage of a single-piece product» is that it integrates several functions and individual parts into one single, space-saving unit. Beam Couplings have no additional moving parts and are therefore wear-free. This also

results in high dynamic stability and vibration-free, smooth running bearing loads, even where there is a large misalignment between shafts.

With the standard couplings, you can choose clamping hubs or set screws to attach the connecting shafts.

You can also freely select the connections you require depending on your specific application. Any material can be used, as long as it is suitable for machining.

RINGSPANN Beam Couplings are used in a wide range of applications. Typical areas of application for Beam Couplings are:

- Encoders
- Tachogenerators
- Spindle drives
- General mechanical engineering
- Apparatus engineering
- Servomotors
- Positioning systems
- Step motors



RBC ... EWS-ALU



RBC ... EWS-STE



RBC ... EWC-ALU



RBC ... EWC-STE



RBC ... DWC-ALU



RBC ... DWC-STE



RBC ... FKC-ALU

Single Beam Couplings RBC ... EWS-ALU

with set screw
made of aluminium

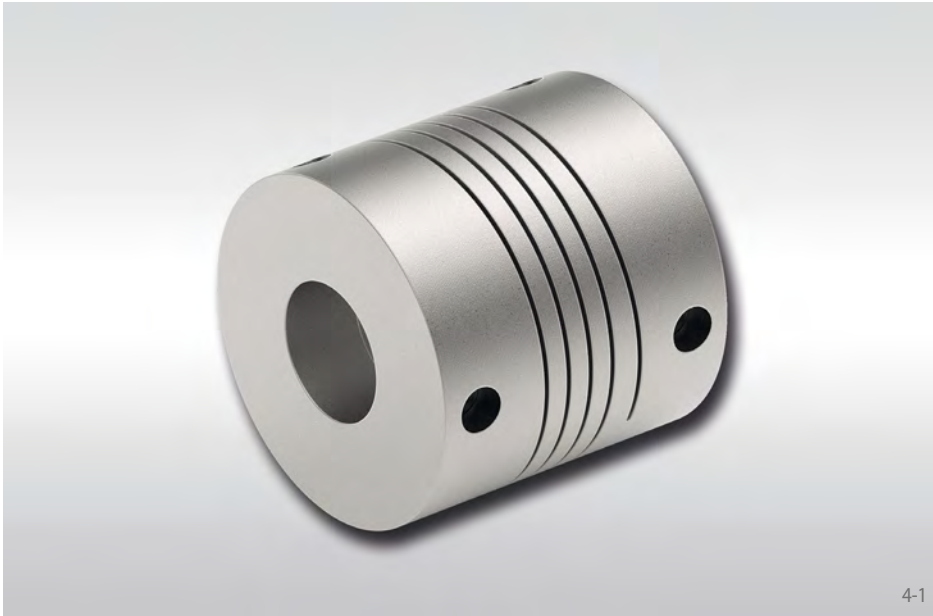

Features

- Small coupling for universal use
- Backlash-free angle-synchronous transmission of rotary movements
- For light applications
- Made of aluminium 7075-T6, material no. 3.4365
- Optimum compensation of shaft misalignments
- Typical applications: Encoders, tachogenerators, spindle drives

Order example

	Code
Coupling design	RBC
Coupling size	0030
Type	EWS
Material: • Aluminium	ALU
Bore diameter d1 = 11 mm	011.00
Bore diameter d2 = 10 mm	010.00

RBC 0030 EWS-ALU-011.00-010.00

Single Beam Couplings RBC ... EWS-ALU

with set screw
made of aluminium

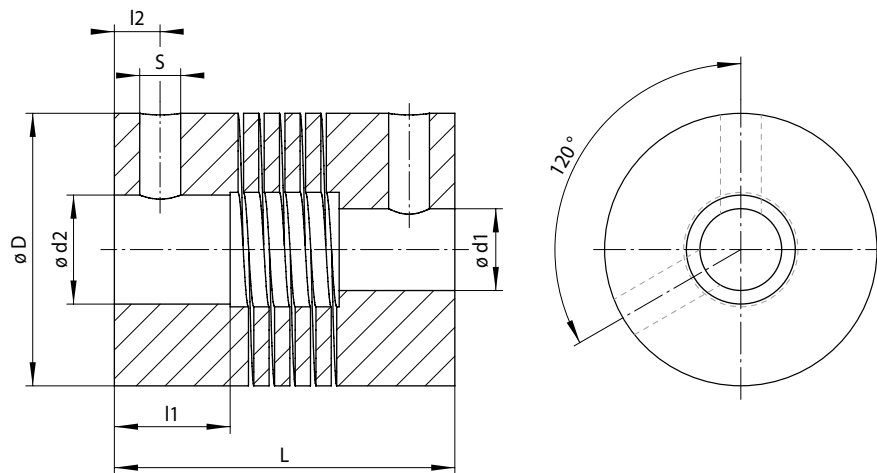

5-1

Coupling size	Standard bore combinations d1 / d2 mm	Torque			Max. speed min ⁻¹	Stiffness			Moment of inertia ¹⁾ x10 ⁻⁶ kgm ²	Screw tightening torque Nm	Permissible shaft misalignment		
		short-term Nm	one-sided Nm	reversing Nm		Torsional stiffness Ct Nm/rad	Radial spring stiffness N/mm	Axial spring stiffness N/mm			Axial mm	Radial mm	Angular °
0015	3/3	0,71	0,36	0,18	10 000	11,2	169	44	0,23	1,0	± 0,25	± 0,25	5
	4/3	0,66	0,33	0,17		8,0	131	29					
	4/4	0,66	0,33	0,17		8,0	131	29					
	5/3	0,59	0,3	0,15		5,7	102	20					
	5/4	0,59	0,3	0,15		5,7	102	20					
0020	5/5	0,59	0,3	0,15	10 000	5,7	102	20	0,78	1,0	± 0,25	± 0,25	5
	4/4	1,3	0,7	0,4		21,2	179	29					
	5/4	1,2	0,6	0,3		16,4	149	21					
	5/5	1,2	0,6	0,3		16,4	149	21					
	6/4	1,1	0,6	0,3		12,7	124	15					
0025	6/5	1,1	0,6	0,3	10 000	12,7	124	15	2,31	2,1	± 0,25	± 0,25	5
	6/6	1,1	0,6	0,3		12,7	124	15					
	6/6	2,9	1,5	0,8		38,2	236	34					
	8/6	2,6	1,3	0,7		26,0	175	21					
	8/8	2,6	1,3	0,7		26,0	175	21					
0030	10/6	2,2	1,1	0,6	10 000	16,4	126	14	5,5	4,7	± 0,25	± 0,25	5
	10/8	2,2	1,1	0,6		16,4	126	14					
	10/10	2,2	1,1	0,6		16,4	126	14					
	10/10	4,6	2,3	1,2		44,1	192	25					
	11/10	4,3	2,2	1,1		35,8	169	21					
0030	11/11	4,3	2,2	1,1	10 000	35,8	169	21	5,5	4,7	± 0,25	± 0,25	5
	12/10	4,0	2,0	1,0		30,2	147	18					
	12/11	4,0	2,0	1,0		30,2	147	18					
	12/12	4,0	2,0	1,0		30,2	147	18					

Bore tolerance: 0/+ 0.05 mm; Shaft tolerance (recommended): - 0.005/- 0.013 mm

¹⁾ Values based on the smallest bore diameter

Coupling size	D mm	L mm	l1 mm	l2 mm	S mm	Weight ¹⁾ g
0015	15	20	4,8	2,5	M3	8
0020	20	20	4,8	2,5	M3	15
0025	25	24	5,9	3,0	M4	28
0030	30	30	6,8	3,5	M5	47

¹⁾ Values based on the smallest bore diameter

Other sizes and designs with special bores (including inch dimensions) on request

Single Beam Couplings RBC ... EWS-STE

with set screw
made of steel, stainless



Features

- Small coupling for universal use
- Backlash-free angle-synchronous transmission of rotary movements
- For medium torques
- Made of stainless steel 17-4PH, Material no. 1.4542
- Optimum compensation of shaft misalignments
- Typical applications: Encoders, tachogenerators, spindle drives

Order example

	Code
Coupling design	RBC
Coupling size	0030
Type	EWS
Material: • Steel, stainless	STE
Bore diameter d1 = 11 mm	011.00
Bore diameter d2 = 10 mm	010.00

RBC 0030 EWS-STE-011.00-010.00

Single Beam Couplings RBC ... EWS-STE

with set screw
made of steel, stainless

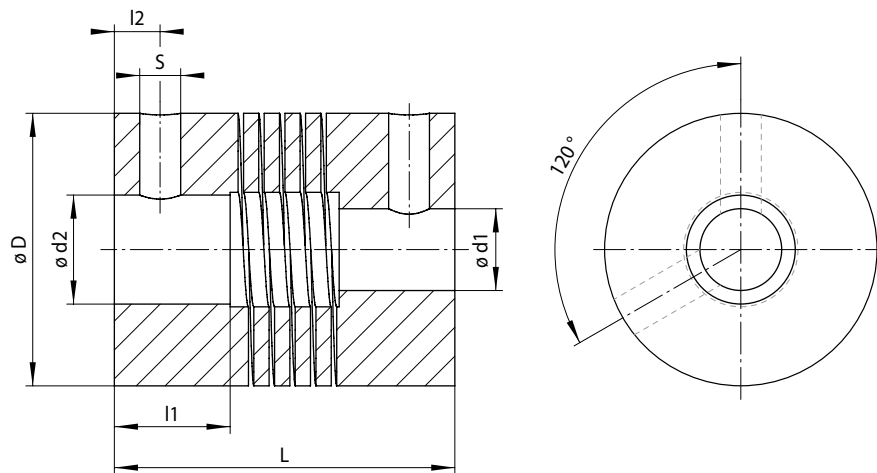

7-1

Coupling size	Standard bore combinations d1 / d2 mm	Torque			Max. speed min ⁻¹	Stiffness			Moment of inertia ¹⁾ x10 ⁻⁶ kgm ²	Screw tightening torque Nm	Permissible shaft misalignment		
		short-term Nm	one-sided Nm	reversing Nm		Torsional stiffness Ct Nm/rad	Radial spring stiffness N/mm	Axial spring stiffness N/mm			Axial mm	Radial mm	Angular °
0015	4 / 4	1,3	0,65	0,33	10 000	22,0	368	81	0,67	1,0	± 0,25	± 0,25	5
	5 / 4	1,2	0,6	0,3		15,5	285	55					
	5 / 5	1,2	0,6	0,3		15,5	285	55					
0020	5 / 5	2,5	1,3	0,7	10 000	44,1	418	58	2,13	1,0	± 0,25	± 0,25	5
	6 / 5	2,3	1,2	0,6		35,8	346	42					
	6 / 6	2,3	1,2	0,6		35,8	346	42					
0025	6 / 6	5,7	2,9	1,5	10 000	101,0	662	95	6,45	2,1	± 0,25	± 0,25	5
	8 / 6	5,1	2,6	1,3		69,9	490	58					
	8 / 8	5,1	2,6	1,3		69,9	490	58					
	10 / 6	4,3	2,2	1,1		44,1	354	38					
	10 / 8	4,3	2,2	1,1		44,1	354	38					
0030	10 / 10	4,3	2,2	1,1	10 000	44,1	354	38	16,2	4,7	± 0,25	± 0,25	5
	10 / 10	8,9	4,5	2,3		119,4	538	71					
	12 / 10	7,7	3,9	2,0		81,9	412	49					
	12 / 12	7,7	3,9	2,0		81,9	412	49					

Bore tolerance: 0/+ 0.05 mm; Shaft tolerance (recommended): - 0.005/- 0.013 mm
¹⁾ Values based on the smallest bore diameter

Coupling size	D	L	l1	l2	S	Weight ¹⁾
	mm	mm	mm	mm	mm	g
0015	15	20	4,8	2,5	M3	23
0020	20	20	4,8	2,5	M3	41
0025	25	24	5,9	3,0	M4	78
0030	30	30	6,8	3,5	M5	132

¹⁾ Values based on the smallest bore diameter
 Other sizes and designs with special bores (including inch dimensions) on request

Single Beam Couplings RBC ... EWC-ALU

with clamp
made of aluminium



Features

- Small coupling for universal use
- Backlash-free angle-synchronous transmission of rotary movements
- For light applications
- Made of aluminium 7075-T6, material no. 3.4365
- Optimum compensation of shaft misalignments
- Typical applications: Encoders, tachogenerators, spindle drives

Order example

	Code
Coupling design	RBC
Coupling size	0030
Type	EWC
Material: • Aluminium	ALU
Bore diameter d1 = 11 mm	011.00
Bore diameter d2 = 10 mm	010.00

RBC 0030 EWC-ALU-011.00-010.00

Single Beam Couplings RBC ... EWC-ALU

with clamp
made of aluminium

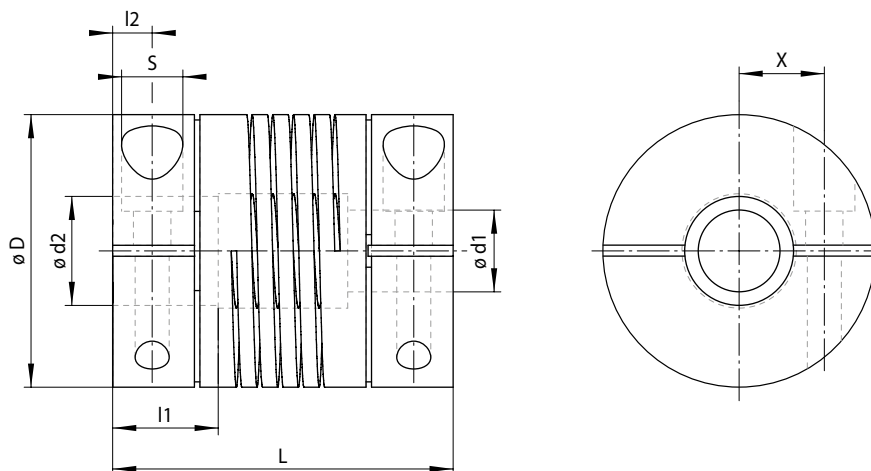

9-1

Coupling size	Standard bore combinations d1 / d2 mm	Torque			Max. speed min ⁻¹	Stiffness			Moment of inertia ¹⁾ x10 ⁻⁶ kgm ²	Screw tightening torque Nm	Permissible shaft misalignment		
		short-term Nm	one-sided Nm	reversing Nm		Torsional stiffness Ct Nm/rad	Radial spring stiffness N/mm	Axial spring stiffness N/mm			Axial mm	Radial mm	Angular °
0015	3/3	0,71	0,36	0,18	10 000	11,2	169	44	0,26	0,5	± 0,25	± 0,25	5
	4/3	0,66	0,33	0,17		8,0	131	29					
	4/4	0,66	0,33	0,17		8,0	131	29					
	5/3	0,59	0,3	0,15		5,7	102	20					
	5/4	0,59	0,3	0,15		5,7	102	20					
0020	5/5	0,59	0,3	0,15	10 000	5,7	102	20	1,09	2,0	± 0,25	± 0,25	5
	4/4	1,3	0,7	0,4		21,2	179	29					
	5/4	1,2	0,6	0,3		16,4	149	21					
	5/5	1,2	0,6	0,3		16,4	149	21					
	6/4	1,1	0,6	0,3		12,7	124	15					
0025	6/5	1,1	0,6	0,3	10 000	12,7	124	15	2,89	2,0	± 0,25	± 0,25	5
	6/6	1,1	0,6	0,3		12,7	124	15					
	6/6	2,9	1,5	0,8		38,2	236	34					
	8/6	2,6	1,3	0,7		26,0	175	21					
	8/8	2,6	1,3	0,7		26,0	175	21					
0030	10/6	2,2	1,1	0,6	10 000	16,4	126	14	7,02	4,7	± 0,25	± 0,25	5
	10/8	2,2	1,1	0,6		16,4	126	14					
	10/10	2,2	1,1	0,6		16,4	126	14					
	8/8	4,9	2,5	1,3		52,1	219	31					
	10/8	4,6	2,3	1,2		44,1	192	25					
0030	10/10	4,6	2,3	1,2	10 000	44,1	192	25	7,02	4,7	± 0,25	± 0,25	5
	12/8	4,0	2,0	1,0		30,2	147	18					
	12/10	4,0	2,0	1,0		30,2	147	18					
0030	12/12	4,0	2,0	1,0	10 000	30,2	147	18	7,02	4,7	± 0,25	± 0,25	5

Bore tolerance: 0/+ 0.05 mm; Shaft tolerance (recommended): - 0.005/- 0.013 mm
¹⁾ Values based on the smallest bore diameter

Coupling size	D	L	l1	l2	S	X	Weight ¹⁾
	mm	mm	mm	mm	mm	mm	g
0015	15	22	6,0	2,5	M2	4,3	9
0020	20	28	8,6	3,7	M3	5,5	21
0025	25	30	8,6	3,7	M3	7,7	35
0030	30	38	11,0	5,0	M4	8,8	60

¹⁾ Values based on the smallest bore diameter
 Other sizes and designs with special bores (including inch dimensions) on request

Single Beam Couplings RBC ... EWC-STE

with clamp
made of steel, stainless



Features

- Small coupling for universal use
- Backlash-free angle-synchronous transmission of rotary movements
- For medium torques
- Made of stainless steel 17-4PH, Material no. 1.4542
- Optimum compensation of shaft misalignments
- Typical applications: Encoders, tachogenerators, spindle drives

Order example

	Code
Coupling design	RBC
Coupling size	0030
Type	EWC
Material: • Steel, stainless	STE
Bore diameter d1 = 11 mm	011.00
Bore diameter d2 = 10 mm	010.00

RBC 0030 EWC-STE-011.00-010.00

with clamp
made of steel, stainless

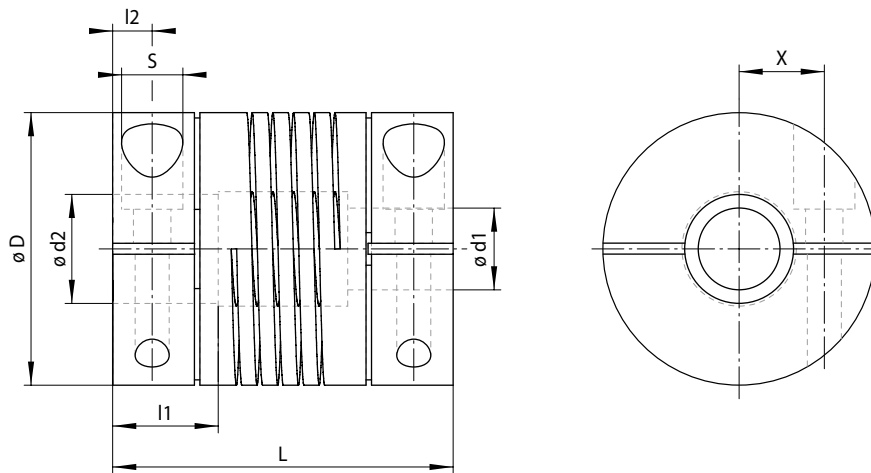

11-1

Coupling size	Standard bore combinations d1 / d2 mm	Torque			Max. speed min ⁻¹	Stiffness			Moment of inertia ¹⁾ x10 ⁻⁶ kgm ²	Screw tightening torque Nm	Permissible shaft misalignment		
		short-term Nm	one-sided Nm	reversing Nm		Torsional stiffness Ct Nm/rad	Radial spring stiffness N/mm	Axial spring stiffness N/mm			Axial mm	Radial mm	Angular °
0020	5 / 5	2,5	1,3	0,7	10 000	44,1	418	58	3,02	2,0	± 0,25	± 0,25	5
	6 / 5	2,3	1,2	0,6		35,8	346	42					
	6 / 6	2,3	1,2	0,6		35,8	346	42					
0025	6 / 6	5,7	2,9	1,5	10 000	101,0	662	95	8,02	2,0	± 0,25	± 0,25	5
	8 / 6	5,1	2,6	1,3		69,9	490	58					
	8 / 8	5,1	2,6	1,3		69,9	490	58					
	10 / 6	4,3	2,2	1,1		44,1	354	38					
	10 / 8	4,3	2,2	1,1		44,1	354	38					
0030	10 / 10	4,3	2,2	1,1	10 000	44,1	354	38	20,5	4,7	± 0,25	± 0,25	5
	10 / 10	8,9	4,5	2,3		119,4	538	71					
	11 / 10	8,3	4,2	2,1		98,8	473	58					
	11 / 11	8,3	4,2	2,1		98,8	473	58					
	12 / 10	7,7	3,9	2,0		81,9	412	49					
	12 / 11	7,7	3,9	2,0		81,9	412	49					
	12 / 12	7,7	3,9	2,0	81,9	412	49						

Bore tolerance: 0/+ 0.05 mm; Shaft tolerance (recommended): - 0.005/- 0.013 mm

¹⁾ Values based on the smallest bore diameter

Coupling size	D	L	l1	l2	S	X	Weight ¹⁾
	mm	mm	mm	mm	mm	mm	g
0020	20	28	8,6	3,7	M3	5,5	58
0025	25	30	8,6	3,7	M3	7,7	97
0030	30	38	11,0	5,0	M4	8,8	167

¹⁾ Values based on the smallest bore diameter

Other sizes and designs with special bores (including inch dimensions) on request

Double Beam Couplings RBC ... DWC-ALU

with clamp
made of aluminium

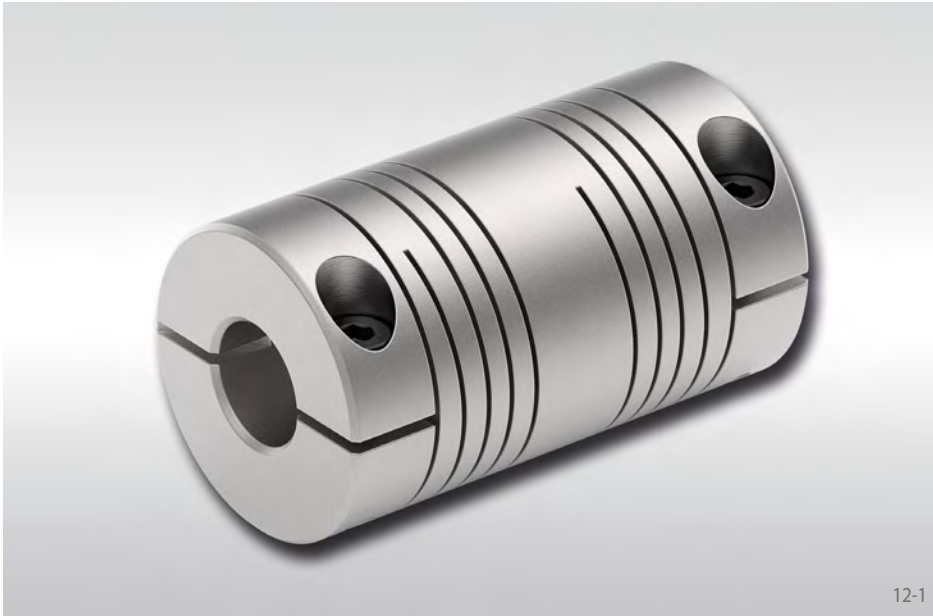

Features

- Small coupling for universal use
- Backlash-free angle-synchronous transmission of rotary movements
- High radial misalignment
- For smaller torques
- Made of aluminium 7075-T6, material no. 3.4365
- Optimum compensation of shaft misalignments
- Typical applications: General mechanical engineering, apparatus engineering, spindle drives

Order example

	Code
Coupling design	RBC
Coupling size	0100
Type	DWC
Material: • Aluminium	ALU
Bore diameter d1 = 10 mm	010.00
Bore diameter d2 = 8 mm	008.00

RBC 0100 DWC-ALU-010.00-008.00

Double Beam Couplings RBC ... DWC-ALU

with clamp
made of aluminium

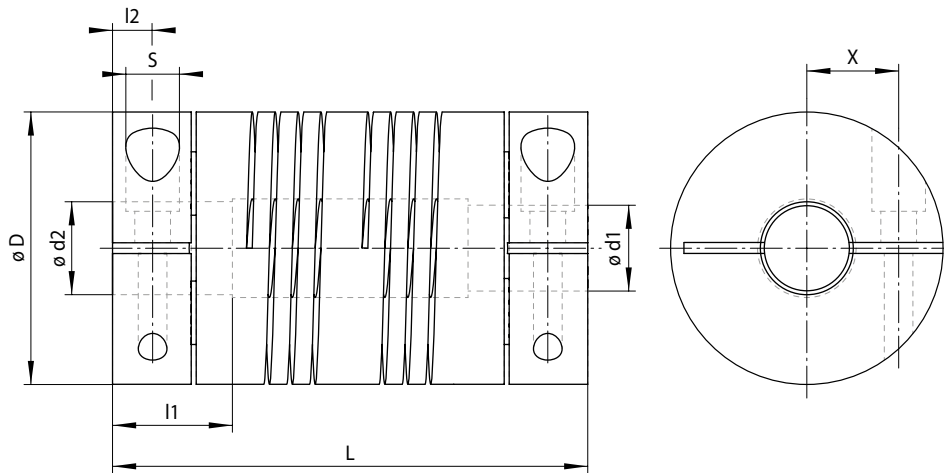

13-1

Coupling size	Standard bore combinations d1 / d2 mm	Torque			Max. speed min ⁻¹	Stiffness		Moment of inertia ¹⁾ x10 ⁻⁶ kgm ²	Screw tightening torque Nm	Permissible shaft misalignment		
		short-term Nm	one-sided Nm	reversing Nm		Torsional stiffness Ct Nm/rad	Axial spring stiffness N/mm			Axial mm	Radial mm	Angular °
0100	6 / 6	3,2	1,6	0,8	3 600	25	20	4,52	2,0	± 0,25	± 0,75	5
	8 / 6	2,7	1,4	0,7		17	13					
	8 / 8	2,7	1,4	0,7		17	13					
	10 / 6	2,3	1,2	0,6		11	8					
	10 / 8	2,3	1,2	0,6		11	8					
	10 / 10	2,3	1,2	0,6		11	8					
0125	8 / 8	6,4	3,2	1,6	3 600	50	23	15,2	4,7	± 0,25	± 0,75	5
	10 / 8	5,5	2,8	1,4		34	16					
	10 / 10	5,5	2,8	1,4		34	16					
	12 / 8	4,1	2,1	1,1		24	11					
	12 / 10	4,1	2,1	1,1		24	11					
0150	10 / 10	12,0	6,0	3,0	3 600	91	38	34,1	4,7	± 0,25	± 0,75	5
	12 / 10	10,3	5,2	2,6		69	28					
	12 / 12	10,3	5,2	2,6		69	28					

Bore tolerance: 0/+ 0.05 mm; Shaft tolerance (recommended): - 0.005/- 0.013 mm

¹⁾ Values based on the smallest bore diameter

Coupling size	D	L	l1	l2	S	X	Weight ¹⁾
	mm	mm	mm	mm	mm	mm	g
0100	25,4	44,5	9,4	3,8	M3	7,9	54
0125	31,8	60,2	13,0	5,6	M4	9,7	113
0150	38,1	66,5	16,8	5,6	M4	13,0	180

¹⁾ Values based on the smallest bore diameter

Other sizes and designs with special bores (including inch dimensions) on request

Double Beam Couplings RBC ... DWC-STE

with clamp
made of steel, stainless



Features

- Small coupling for universal use
- Backlash-free angle-synchronous transmission of rotary movements
- High radial misalignment
- For medium torques
- Made of stainless steel 17-4PH, Material no. 1.4542
- Optimum compensation of shaft misalignments
- Typical applications: General mechanical engineering, apparatus engineering, spindle drives

Order example

	Code
Coupling design	RBC
Coupling size	0100
Type	DWC
Material: • Steel, stainless	STE
Bore diameter d1 = 10 mm	010.00
Bore diameter d2 = 8 mm	008.00

RBC 0100 DWC-STE-010.00-008.00

Double Beam Couplings RBC ... DWC-STE

with clamp
made of steel, stainless

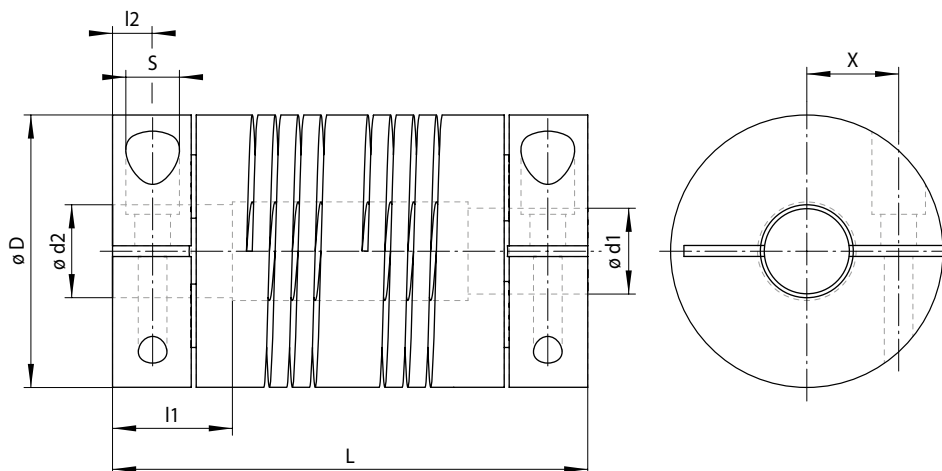

15-1

Coupling size	Standard bore combinations d1 / d2 mm	Torque			Max. speed min ⁻¹	Stiffness		Moment of inertia ¹⁾ x10 ⁻⁶ kgm ²	Screw tightening torque Nm	Permissible shaft misalignment		
		short-term Nm	one-sided Nm	reversing Nm		Torsional stiffness Ct Nm/rad	Axial spring stiffness N/mm			Axial mm	Radial mm	Angular °
0100	6 / 6	6,8	3,4	1,7	3 600	70	56	12,6	2,0	± 0,25	± 0,75	5
	8 / 6	5,9	3,0	1,5		47	36					
	8 / 8	5,9	3,0	1,5		47	36					
	10 / 6	5,0	2,5	1,3		30	22					
	10 / 8	5,0	2,5	1,3		30	22					
	10 / 10	5,0	2,5	1,3		30	22					
0125	8 / 8	14,2	7,1	3,6	3 600	130	64	42,3	4,7	± 0,25	± 0,75	5
	12 / 8	9,6	4,8	2,4		66	31					
	12 / 12	9,6	4,8	2,4		66	31					
	15 / 8	7,3	3,7	1,8		29	17					
	15 / 12	7,3	3,7	1,8		29	17					
0150	15 / 15	7,3	3,7	1,8	3 600	29	17	96,1	4,7	± 0,25	± 0,75	5
	12 / 12	23,5	11,8	5,9		190	78					
	14 / 12	20,7	10,4	5,2		143	60					
	14 / 14	20,7	10,4	5,2		143	60					
	16 / 12	17,5	8,8	4,4		105	46					
	16 / 14	17,5	8,8	4,4		105	46					
16 / 16	17,5	8,8	4,4	105	46							

Bore tolerance: 0/+ 0.05 mm; Shaft tolerance (recommended): - 0.005/- 0.013 mm

¹⁾ Values based on the smallest bore diameter

Coupling size	D	L	l1	l2	S	X	Weight ¹⁾
	mm	mm	mm	mm	mm	mm	g
0100	25,4	44,5	9,4	3,8	M3	7,9	150
0125	31,8	60,2	13,0	5,6	M4	9,7	315
0150	38,1	66,5	16,8	5,6	M4	13,0	507

¹⁾ Values based on the smallest bore diameter

Other sizes and designs with special bores (including inch dimensions) on request

Cross-Slotted Couplings RBC ... FKC-ALU

with clamp
made of aluminium



Features

- Backlash-free, torsionally rigid Cross-Slotted Coupling
- For backlash-free drives with fast start/stop cycles
- For medium torques
- Made of aluminium 7075-T6, material no. 3.4365
- Typical applications: Servomotors, positioning systems, step motors

Order example

	Code
Coupling design	RBC
Coupling size	0025
Type	FKC
Material: • Aluminium	ALU
Bore diameter d1 = 10 mm	010.00
Bore diameter d2 = 8 mm	008.00

RBC 0025 FKC-ALU-010.00-008.00

Cross-Slotted Couplings RBC ... FKC-ALU

with clamp
made of aluminium

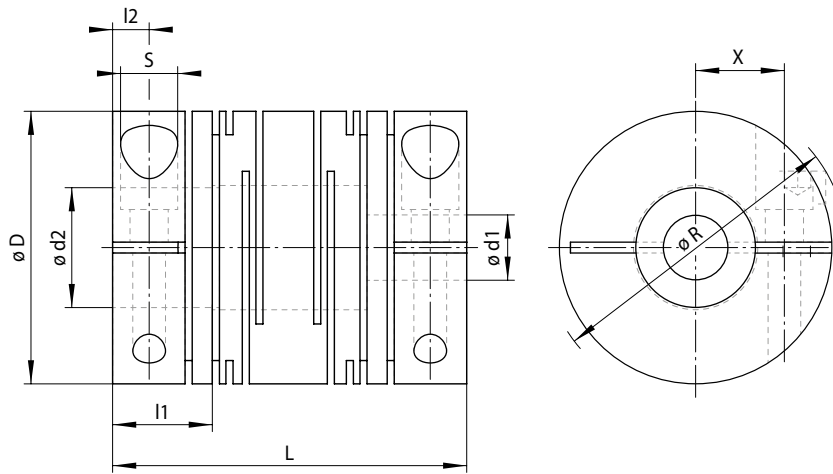

17-1

Coupling size	Standard bore combinations d1 / d2 mm	Torque constantly reversing Nm	Max. speed min ⁻¹	Stiffness Torsional stiffness Ct Nm/rad	Moment of inertia ¹⁾ x10 ⁻⁶ kgm ²	Screw tightening torque Nm	Permissible shaft misalignment		
							Axial mm	Radial mm	Angular °
0015	3 / 3	0,3	10 000	51	0,27	1,1	± 0,25	± 0,1	3
	5 / 3								
	5 / 5								
0020	4 / 4	0,5	10 000	125	1,04	2,0	± 0,25	± 0,1	3
	6 / 4								
0025	6 / 6	1,0	10 000	261	2,73	2,0	± 0,25	± 0,15	3
	8 / 6								
	8 / 8								
	10 / 6								
	10 / 8								
0030	10 / 10	2,0	10 000	441	7,36	4,7	± 0,25	± 0,15	3
	12 / 10								
	12 / 12								

Bore tolerance: 0/+ 0.05 mm; Shaft tolerance (recommended): - 0.005/- 0.013 mm

¹⁾ Values based on the smallest bore diameter

Coupling size	D	L	l1	l2	S	R	X	Weight ¹⁾
	mm	mm	mm	mm	mm	mm	mm	g
0015	15	24	6,3	3,0	M2,5	17,5	5,0	9
0020	20	28	7,9	3,8	M3	-	5,4	20
0025	25	30	8,0	3,8	M3	-	7,7	33
0030	30	38	10,3	5,0	M4	-	9,1	60

¹⁾ Values based on the smallest bore diameter

Other sizes and designs with special bores (including inch dimensions) on request

Shaft misalignments

The RINGSPANN couplings are suitable for a highly diverse range of applications. Precise transmission of the rotational movement with

high angle accuracy is a typical feature of the «single-piece coupling». As a flexible shaft connection, the coupling is able to correctly

compensate different shaft misalignments simultaneously, such as angular, radial, axial and skewed (three-dimensional) misalignments.

Angular misalignment

Angular misalignment is relatively common. In the case of the Beam Coupling, it is compensated for by the fact that the inner edges close while the outer edges expand. If there is sufficient space between the helix groove, misalignments of 20° or greater are possible.



18-1

Radial misalignment

The compensation of radial misalignment places high technical demands on a coupling. If the misalignments in a coupling system cannot be compensated, the resulting lateral forces damage the bearing points. The beam principle offers the ideal solution. The maximum permissible values in the standard catalogue range are ± 0.8 mm. Customer-specific applications allow for even greater values.



18-2

Skewed misalignment (three-dimensional)

In this case, the drive shafts do not share a common plane. The Beam Coupling can even compensate for this three-dimensional misalignment. However, this requires a relatively long beam.



18-3

Optimised torque capacity

Factors such as dynamic load, vibrations, impacts, and additional offsets all have an influence on the transferable torque. The permissible cou-

pling torque is calculated based on the technical material data. Once all operating conditions are known and if these do not deviate from the

catalogue specifications, the Beam Coupling is suitable for an almost infinite service life in terms of torque transfer.

Low bearing load

When compensating for shaft misalignments, couplings generate restoring forces that also act on the connected shafts and their bearings. The possible damages depend on the load direction

and speed. This applies in particular to radial misalignments.

The design of RINGSPANN Beam Couplings ensures constantly low restoring forces at all points across the entire speed range and thus protects the connected components.

Optimum speed behaviour

Due to their design and precise manufacturing, RINGSPANN Beam Couplings guarantee a uniform speed transmission across a wide speed

range without significant vibrations or imbalances.

Configurable torsional stiffness

The torsional stiffness of the standard couplings can be found in the table values. For customer-specific applications, this can be adapted as required, taking into account the technical spec-

ifications. A certain torsional flexibility nonetheless remains in all shaft connections.

Speeds

Thanks to low mass moments of inertia, Beam Couplings can be used over an extensive range of speeds, as well as in reverse operation and for a very high number of cycles.

Our standard Beam Couplings are designed for maximum speeds of up to $10\,000\text{ min}^{-1}$. For specific applications, speeds of $50\,000\text{ min}^{-1}$ have already been successfully achieved. Please con-

tact our technology department for information on suitable applications.

Constant speed

Since the Beam Coupling is machined from a single piece, the minimal manufacturing tolerances enable high-precision work at a constant angu-

lar velocity at both the drive and output ends. Regardless of the misalignment, the angle synchronisation of the connected shafts remains

constant at all times. The integrity of the «one-piece design» ensures there is backlash-free and no imbalance.

Axial compensation

Axial play may be a desirable feature in some systems, or can be a result of the different tolerances of the individual components during assembly, or due to temperature changes, distortion, etc.

The permissible axial offset of the standard couplings is listed in the table values. The axial pressure generated by the torque is reduced to a negligible minimum. For customer-specific configurations, the required axial offset can be cal-

culated and the coupling machined accordingly.

Vibration damping

The screw-shaped, flexible coupling profile helps to considerably reduce unwanted torsional vibrations of a rotating system. The Beam

Couplings are smooth running and do not generate any of their own vibrations.

Bore types and fastening

Bore types

There are basically two basic forms:

Couplings with a continuous internal bore

Recessed coupling

- Internal diameter is greater than the shaft diameter
- The shaft ends should not touch each other, otherwise misalignments can no longer be adequately compensated for

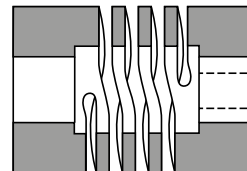

20-1

Offset alignment

- Internal diameter is smaller than the larger shaft diameter, but larger than the smaller shaft diameter
- The shaft ends should not touch each other, otherwise misalignments can no longer be adequately compensated for

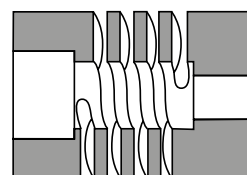

20-2

Limited shaft length

- Internal diameter and both shaft diameters are the same size
- The shaft ends must not protrude into the slotted area of the coupling, otherwise misalignments can no longer be adequately compensated for
- Coupling can be installed or removed by sliding onto a shaft

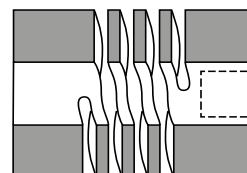

20-3

Offset shaft diameter

- Internal diameter is smaller than the shaft diameter.
- Shafts cannot touch
- The advantage is high torsional stiffness with small couplings

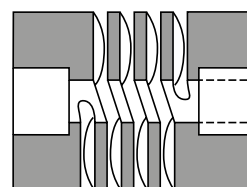

20-4

Blind bores or non-continuous bore

Compared to the other designs, this design transmits a higher torque and higher torsional stiffness with a smaller external diameter and shorter length. However, the coupling is still axially rigid and can only be used to compensate for angular misalignment.

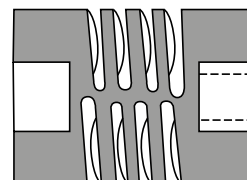

20-5

Fastening

In addition to the two standard types of fastening (set screws and clamps), other common or customized types of connection can be supplied:

- Set screw or clamp at different ends
- Pins, bolts, pegs
- Key
- Flange
- Threaded pin, threaded bore
- Conical bore
- Single or double flattened bore
- Spline toothing

The attachment friction generated at the clamp connection is sufficient to transmit the required torque. No additional key is required. On request and for special applications, however, a clamp connection with a key can be supplied.

As mentioned at the beginning, the versatile application possibilities of a precision shaft coupling are not limited to the catalogue series.

Customer-specific solutions are our speciality. Beam Couplings have even been used for very smallest of couplings, such as those used in microdevices implanted in the human body. This is where the advantage of the free selection of materials for RINGSPANN Beam Couplings comes to the fore.

Customer benefit

The function integration (e.g. coupling/pinion) can increase the service life and safety of the component. At the same time, the overall costs (component costs, assembly, procurement) are also optimised.

Advantages

Reduction in overall costs

- Fewer components for one function
- Shorter assembly times
- Minimised procurement work

Increased safety

- Only one component – clear interfaces
- A point of contact for several functions
- Increased system safety and quality standard

The storage and administration costs are optimised

- Fewer components in the warehouse
- Reduction in orders and suppliers

Reduced development workload

- We can compile design proposals on request, free of charge
- Use of our calculation software



Industry: Food industry

Application: Corrosion-resistant coupling with an integrated pinion for an adjustment unit

Design parameters

As described in the technical principles, the Beam Coupling can also be machined according to your specific requirements. The following parameters influence the properties of the coupling and can be taken into account for the application:

- Beam design
- Beam length
- Number of beams (multistart)
- Bore diameter
- Different coil crosssections
- Material

Coil thickness

By changing the beam pitch, the altered thickness of the coil influences the torque, torsional stiffness, and the axial motion.



22-1

Beam length

If the beam length is changed, the torque remains constant, while all other characteristics may vary depending on the configuration.



22-2

Number of beam starts

Depending on the design requirements, Beam Couplings can also be created

- with a single beam (standard version)
- with a double beam (start offset by 180°)
- with a triple beam (start offset by 120°)

When a so called multistart beam is used, the torque, torsional stiffness, and concentricity are increased. While misalignment capabilities are reduced compared to singlestart beams.



22-3

Bore diameter

Different bore diameters with the same beam configuration and the same external diameter can result in changes to the torque, torsional stiffness, and spring action.



22-4

Material

The Beam Couplings are machined in series production from aluminium alloys (3.4365) with an anodised surface, or from corrosion-resist-

ant chromium nickel steel (1.4542). For specific applications, the customer can also select their own material, such as plastic or titanium. The

only prerequisite is that the material has to be suitable for machining.

Questionnaires for customized Beam Couplings

Please photocopy or use the technical query from our website (www.ringspann.com)!

Company:

Phone:

Name:

E-Mail:

Date:

1. Coupling and shaft dimensions

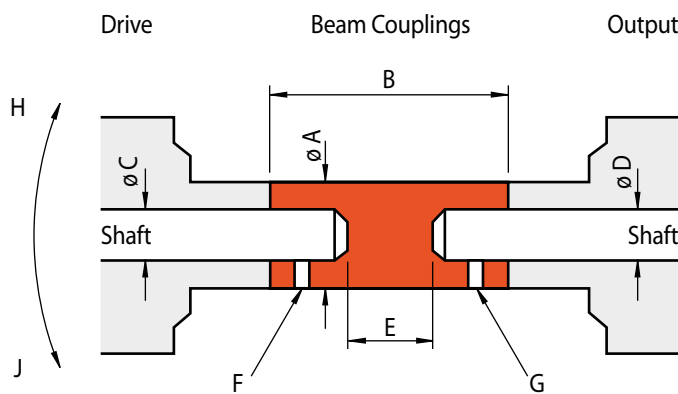

Permissible outside diameter A _____ [mm]

Permissible total length B _____ [mm]

Shaft diameter (drive) C _____ [mm]

Bore tolerance (normal) + 0.05
0.00 mm

Bore tolerance (precise) + 0.015
0.00 mm

Shaft diameter (output) D _____ [mm]

Bore tolerance (normal) + 0.05
0.00 mm

Bore tolerance (precise) + 0.015
0.00 mm

Shaft distance E _____ [mm]

2. Description of drive/output

Drive:

Output:

Direction of rotation H J

continuous reversing operation

Stop/Start _____ [x/sec.]

Revolutions _____ [min⁻¹] by hand

3. Fastening

Drive side F Output side G

Integrated clamps

2 locking screws 120°

2 locking screws 90°

1 locking screw

Cylindrical pins _____ [mm]

Dowel pins _____ [mm]

Key groove _____ [mm]

Other _____ [mm]

4. Operating data

Torque Nominal torque _____ [Nm]

Max. torque _____ [Nm]

Misalignment Angular misalignment _____ [°]

(see p. 20/21) Radial misalignment _____ [mm]

Axial comp./Extension _____ [mm]

No overlap (drawing enclosed)

Torsional stiffness < = > _____ [Nm/rad]

Moment of inertia < = > _____ [kg/cm²]

Weight < = > _____ [g]

Operating conditions Temperature _____ [°C]

Corrosion Dirt

5. Appendices

Specifications

Data sheet

Sketch/drawing

Examples of various customized Beam Couplings

Industry

Aerospace

Application

Beam Coupling with square shaft and gear wheel. Fuel pump control for small aircraft.



24-1

Industry

Food & Packaging

Application

Coupling set with spline tooting for high axial compensation and easy plug-in assembly.



24-2

Industry

Pulp and Paper

Application

Beam Coupling with integrated external and internal thread. Used in clamping clutches for radial and axial compensation to the pressure roller.



24-3

Industry

Medical

Application

Beam Coupling with half-shell on one side and integrated output shaft. Used in foot pedal actuation to control the speed of a surgical instrument.



24-4

Examples of Precision Springs

Customized Precision Springs

The shape of a Beam Coupling, or the actual beam, is basically the same as a spring. Due to this fact, it is possible to manufacture not only couplings but also customized springs with high precision.



25-1

Germany

RINGSPANN GmbH

Schaberweg 30-38, 61348 Bad Homburg
Germany • +49 6172 275 0
info@ringspann.de • www.ringspann.de

RINGSPANN RCS GmbH

Hans-Mess-Straße 7, 61440 Oberursel, Germany
+49 6172 67 68 50
info@ringspann-rcs.de • www.ringspann-rcs.de

France

SIAM - RINGSPANN S.A.

23 rue Saint-Simon, 69009 Lyon, France
+33 4 78 83 59 01
info@siam-ringspann.fr • www.ringspann.fr

Great Britain, Ireland

RINGSPANN (U.K.) LTD.

3, Napier Road, Bedford MK41 0QS, Great Britain
+44 1234 3425 11
info@ringspann.co.uk • www.ringspann.co.uk

Italy

RINGSPANN Italia S.r.l.

Via A.D. Sacharov, 13, 20812 Limbiate (MB), Italy
+39 02 93 57 12 97
info@ringspann.it • www.ringspann.it

Asia

Australia, New Zealand

RINGSPANN Australia Pty Ltd

10 Network Drive, Carrum Downs Vic 3201,
Australia • +61 3 9069 0566
info@ringspann.com.au • www.ringspann.com.au

China, Taiwan

RINGSPANN Power Transmission (Tianjin) Co., Ltd.

No. 21 Gaoyan Rd., Binhai Science and Technology
Park, Binhai Hi-Tech Industrial, Development Area,
Tianjin, 300458, P.R. China • +86 22 5980 31 60
info.cn@ringspann.cn • www.ringspann.cn

America

Brazil

Antares Acoplamentos Ltda.
Rua Evaristo de Antoni, 1222, Caxias do Sul, RS,
CEP 95041-000, Brazil • +55 54 32 18 68 00
vendas@antaresacoplamentos.com.br
www.antaresacoplamentos.com.br

Africa and Middle East

Egypt

Shofree Trading Co.
218 Emtedad Ramsis 2, 2775 Nasr City, Cairo, Egypt
+20 2 2081 2057
info@shofree.com • www.ringspann.com

Israel

G.G. Yarom Rolling and Conveying Ltd.
6, Hamaktesh Str., 58810 Holon, Israel
+972 3 557 01 15
noam_a@gg.co.il • www.ringspann.com

Netherlands, Belgium, Luxembourg

RINGSPANN Benelux B.V.

Nieuwenkampsmeden 6-15, 7472 DE Goor,
Netherlands • +31 547 26 13 55
info@ringspann.nl • www.ringspann.nl

Austria, Czech Republic,
Hungary, Slovakia, Slovenia**RINGSPANN Austria GmbH**

Triesterstraße 21, 2620 Neunkirchen, Austria
+43 2635 62446
info@ringspann.at • www.ringspann.at

Poland

Radius-Radpol Wiecheć Sp.J.
Ul. Pasjonatów 3, 62-070 Dąbrowa, Poland
+48 61 814 39 28 • info@radius-radpol.com.pl
www.radius-radpol.com.pl

Romania, Bulgaria, Moldova

S.C. Industrial Seals and Rolls S.R.L.
Str. Depozitelor, No. 29, 110078 Pitesti, Romania
+4 0751 228228
mihai@isar.com.ro • www.isar.com.ro

Sweden, Finland, Denmark,
Norway, Baltic states**RINGSPANN Nordic AB**

Flottiljgatan 69, 721 31 Västerås, Sweden
+46 156 190 98
info@ringspann.se • www.ringspann.se

India, Bangladesh, Nepal

RINGSPANN Power Transmission India Pvt. Ltd.

GAT No: 679/2/1, Village Kuruli, Taluka Khed, Chakan-
Alandi Road, Pune - 410501, Maharashtra, India
+91 21 35 67 75 00 • info@ringspann-india.com
www.ringspann-india.com

Singapore, ASEAN

RINGSPANN Singapore Pte. Ltd.

143 Cecil Street, #17-03 GB Building,
Singapore 069542 • +6012 5898975
info@ringspann.sg • www.ringspann.sg

Chile, Peru, Colombia, Ecuador

RINGSPANN Sudamérica SpA

Miraflores 222, Piso 28-N, Santiago,
Región Metropolitana, Chile • +56 9 9147 2833
info@ringspannsudamerica.com
www.ringspannsudamerica.com

South Africa, Sub-Saharan

RINGSPANN South Africa (Pty) Ltd.

96 Plane Road Spartan, Kempton Park,
P.O. Box 8111 Edenglen 1613, South Africa
+27 11 394 1830
info@ringspann.co.za • www.ringspann.co.za

Switzerland

RINGSPANN AG

Sumpfstrasse 7, P.O. Box, 6303 Zug,
Switzerland • +41 41 748 0900
info@ringspann.ch • www.ringspann.ch

Spain, Portugal

RINGSPANN IBERICA S.A.

C/Uzbina, 24-Nave E1, 01015 Vitoria, Spain
+34 945 2277-50
info@ringspann.es • www.ringspann.es

Ukraine

"START-UP" LLC.

Saltivske Hwy, 43, letter G-3, office 101,
Kharkiv 61038, Ukraine • +38 057 717 03 04
start-up@start-up.kh.ua • www.start-up.kh.ua

South Korea

RINGSPANN Korea Ltd.

33 Gojae-17 Ghil Dongnam-gu, 31187 Cheonan-si
Chungnam, South Korea • +82 10 54961 368
info@ringspann.kr • www.ringspann.kr

USA, Canada, Mexico

RINGSPANN Corporation

10550 Anderson Place, Franklin Park, IL 60131, USA
+1 847 6783581
info@ringspanncorp.com
www.ringspanncorp.com